

Extra Large IP Display with InformaCast®

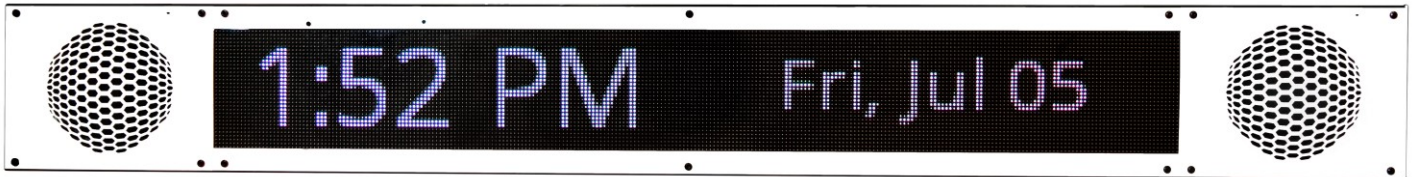

Description

Wahsega's line of PoE-enabled IP Displays enables continuous time and date display and also allows for critical textual information to be scrolled on the display. The Wahsega POE-enabled Extra Large IP Display with InformaCast® has a 40-inch wide LED display which supports over 32,000 colors with an LED resolution that is twice what competing products provide. All text is rendered using vector fonts, allowing for improved readability.

The Wahsega Extra Large IP Display with InformaCast® supports dual registration with InformaCast® and SIP as well as multicast for background music. With network connectivity, scrolling LED display, built-in speaker and multi-color flashers, the Wahsega Extra Large IP Display with InformaCast® broadcasts both audible and visible messages to hallways, classroom, offices and large rooms.

Two integrated relays let building managers remotely control external devices. A built-in microphone allows for two-way SIP communication, and time synchronization is handled by a network SNTP Server.

The Wahsega POE-enabled Extra Large IP Display with InformaCast® can even power a second, auxiliary Extension Speaker (WL-SPKR-22-A or WL-SPKR-SMT-A) up to 20 meters away via an Ethernet cable, increasing the audio coverage in the space.

Job Name: **Model Numbers:** **Date:**

Location: **Notes:**

Features

- Dual registration: SIP and InformaCast
- Automatic InformaCast server registration
- PoE 802.3af enabled
- Able to drive second Wahsega analog speaker $\leq 20\text{m}$ away via Cat5e or Cat6
- Fully configurable via simple webpages
- Multiple audio codecs to choose from
- Simple surface-mount wall installation
- Built-in microphone for two-way communication
- Web-based mic and speaker volume control
- Classroom sound reinforcement audio input wallplate available
- Status feedback
- Two onboard relays for door control
- Text display up to 5" high
- RJ45 connections for simplified installation of second speaker and remote sound reinforcement wallplate
- Compatible with standard panic buttons
- Advanced panic button functionality to reduce false alarm triggers
- One to three lines of text display
- Time set by network SNTP Server with no manual adjustments necessary
- Receive bell and event schedule alerts from InformaCast or third party
- Display 12- or 24-hour clock with four or six numerals
- Auto-dim feature for energy reduction
- Text display is configurable for scrolling of page by page mode.
- 32,768 LED colors
- 32 x 64 resolution

Specifications

- Ethernet: 10/100 Mbps
- Power Input: PoE 802.3af
- Standby power: < 2 Watts
- Protocol: SIP RFC 3261 compatible
- Audio Codecs: G.711, G.726, G.722, G.729, DVI4, Linear PCM, iLBC, Speex, SILK, Opus
- Audio Sampling: CD audio of 44.1kHz for InformaCast® high quality announcements
- Speaker Drive Capabilities: 8W (5W per speaker when driving two speakers)
- Speaker Impedance: 8Ω
- Speaker Sensitivity: 96dB 1W/0.5M SPL
- Coverage Angle: $120^\circ / 4$ kHz
- Dry Contact Relay Rating: 2A min, 250V AC, 24V DC
- Max PoE Cable Length: 100m (per standard) PoE 10/100 cable length
- Max Secondary Speaker Cat5e or Cat6 Cable Length: 20m
- Temperature Range: -40°C to $+60^\circ\text{C}$
- Weight: 24.5 lbs
- Overall Dimensions: 58.64" W x 7.00" H x 4.54" D
- LED Panel Dimensions: 5" tall x 40" wide
- Construction: Metal housing with polyester powdercoat paint
- Warranty: 2 years limited

Job Name: **Model Numbers:** **Date:**

Location: **Notes:**

Model Numbers

WL-IPD-SPKR-540-INF

Wahsega Labs	Display	Speaker	Display Height	Display Width	Protocol
WL	IPD	SPKR	5	40	INF
Wahsega Labs	IP Display	with Speaker	5 = 5" High Display	10 = 10" Wide Display 20 = 20" Wide Display 30 = 30" Wide Display 40 = 40" Wide Display D = Double Sided	CAR = Carina INF = InformaCast

Installation

Simple, surface mount wall installation with rear and side access for wiring. Power supplied via Power over Ethernet (PoE) 802.3af. The Wahsega Extra Large IP Display with InformaCast mounts to the front of four (4) single-gang or two-gang electrical backboxes or to the surface of a wall, using its included mounting brackets and the appropriate wall anchors for the mounting surface.

Job Name: **Model Numbers:** **Date:**

Location: **Notes:**

Dimensions

Front View

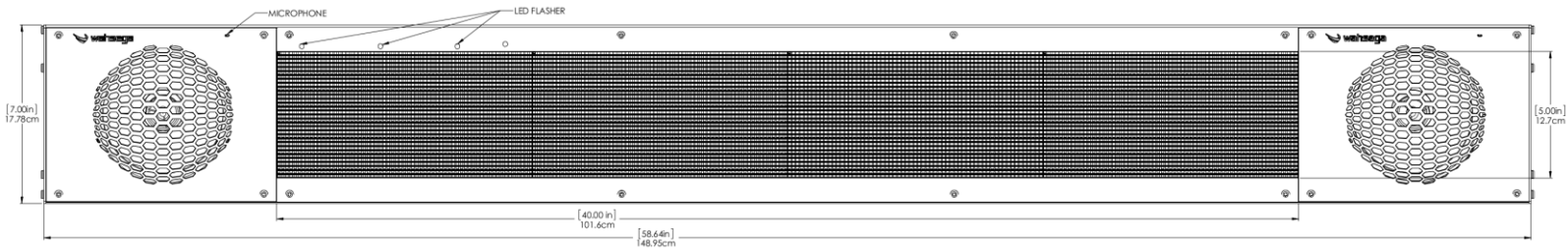

Rear View

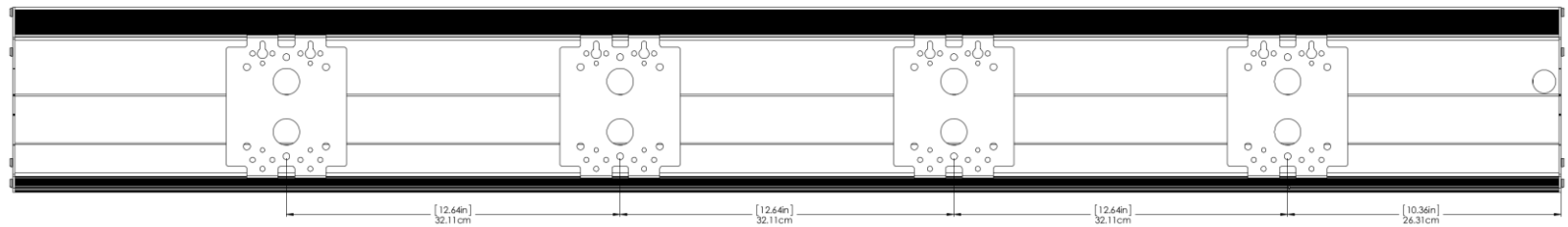

Job Name: Model Numbers: Date:

Location: Notes:

Side View

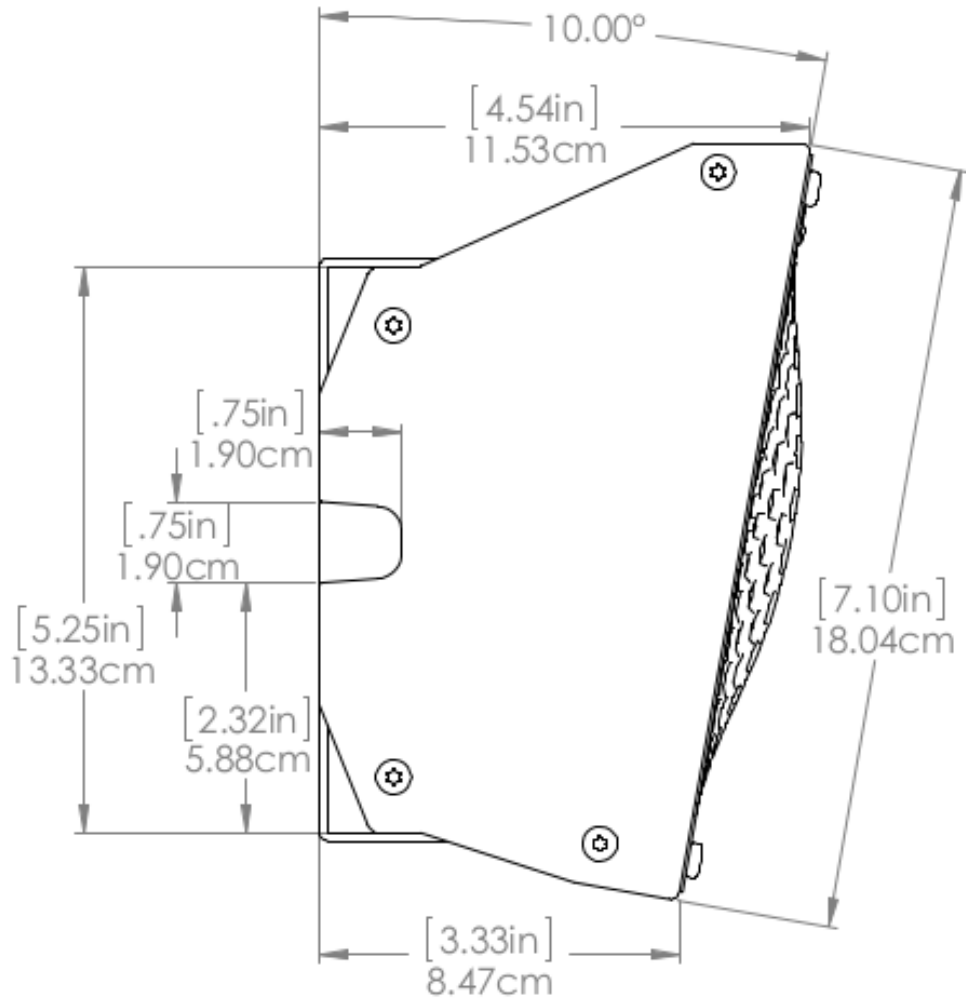

Job Name:

Model Numbers:

Date:

Location:

Notes:

Mounting Bracket

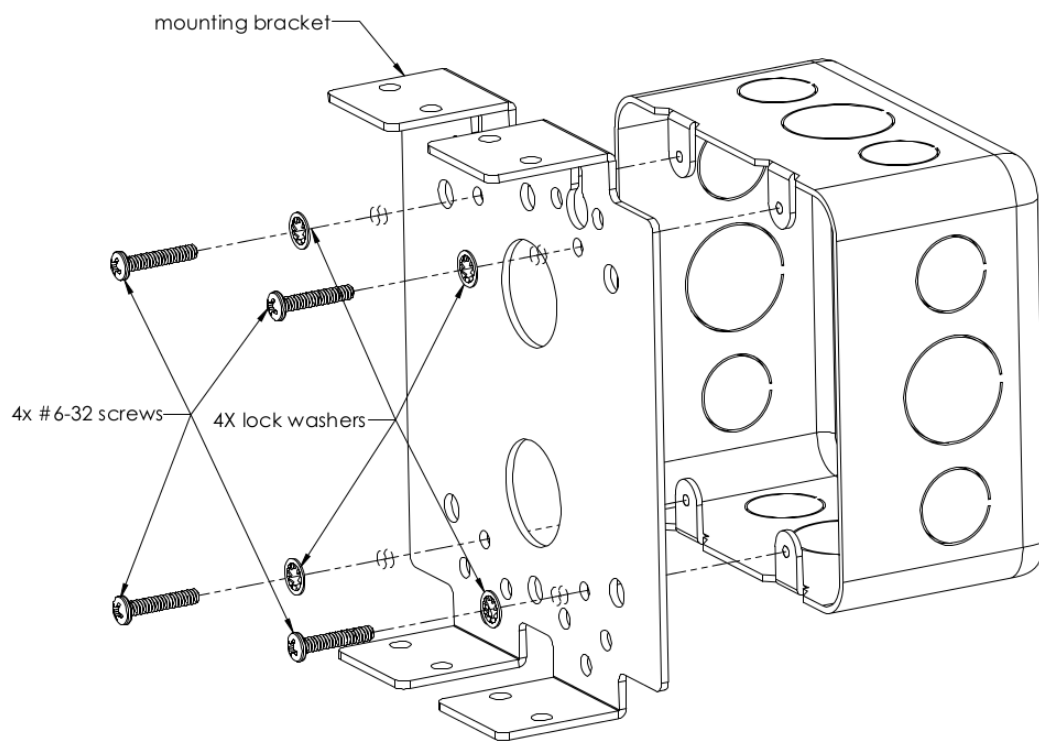

Job Name:

Model Numbers:

Date:

Location:

Notes: