



Carina Double Sided Wall Mount IP Display

Model No: WL-IPD-SPKR-510D-CAR-F

Description

The Carina Double Sided Wall Mount IP Display supports auto-discovery by the Carina Event Manager and registration with SIP. With network connectivity, the device features a scrolling LED display and built-in speaker to convey both audio and visual alerts from the Carina Event Manager to occupants in the room. The settings for LED text, flasher color, brightness and duration are all fully customizable from the Event Manager. A built-in microphone allows for two-way intercom communication. The Event manager's NTP service provides an accurate time and date display when not broadcasting streaming events. The Carina IP Display can also power a second analog Wahsega speaker (WL-SPKR-xx-A) up to 20 meters away via PoE cable, increasing audio coverage in the space without requiring an additional cable home run.

Key Features

- PoE 802.3af enabled (Power-over-Ethernet)
- Industry-leading low standby power
- Fully configurable via Carina Event Manager
- Integrated microphone
- Two onboard relays for door control
- Compatible with standard call buttons
- Web-based mic and speaker volume control
- RJ45 connections for simplified installation
- One to three lines of text display
- Time set by network SNTP Server with no manual adjustments necessary
- Display 12- or 24-hour clock with four or six numerals
- Two color-configurable LED flashers
- One white LED flasher
- Text display is configurable
- 32,768 LED colors
- 32 x 64 resolution
- Text display up to 5" high

Job Name:	Date:	Location:
Notes:		

Carina Double Sided Wall Mount IP Display

Model No: WL-IPD-SPKR-510D-CAR-F

Specification Submittal

Specifications

- Ethernet: 10/100 Mbps
- Power Input: PoE 802.3af
- Standby power: <2 Watts
- Protocol: SIP RFC 3261 compatible
- Audio Codecs: 16-bit PCM (uncompressed), u-law (G.711u), a-law (G.711a), G.722, G.729
- Audio Sampling: 8 kHz, 16 kHz, or 32 kHz
- Speaker Drive Capabilities: 5W
- Speaker Impedance: 8Ω
- Speaker Sensitivity: 96dB 1W/0.5M SPL
- Coverage Angle: 120° / 4 kHz
- Dry Contact Relay Rating: 2A min, 250V AC, 24V DC
- Max PoE Cable Length: 100m (per standard) PoE 10/100 cable length
- Max Auxiliary Speaker Cable Length (Cat5e or Cat6): 20m
- Temperature Range: -40°C to +60°C
- Weight: 13.25 lbs
- Overall Dimensions: 20.39" W x 7.74" H x 8.25" D (bracket adds 4.95" W)
- LED Panel Dimensions: 5" tall x 10" wide
- Construction: Metal housing with polyester powdercoat paint
- Warranty: 3 years limited

Installation

The Wahsega Double Sided Wall Mount IP Display mounts to the surface of a wall, using its included mounting bracket and ½" bolts with the appropriate anchors for your surface material. An earthquake cable is connected to the included eye bolt for further stability. Power supplied via Power over Ethernet (PoE) 802.3af.

Compatibility

Extension Speakers

- 2x2 Extension Ceiling Speaker - WL-SPKR-22-A
- Wall Mount Extension Speaker - WL-SPKR-SMT-A

Accessories

- Teacher Mic Kit - WL-MIC-WIR-KIT-1-CAR
- Sound Reinforcement Panel - WL-SPKR-RSR-W
- Call / Panic Button - WL-SPKR-RB-W

Job Name:	Date:	Location:
Notes:		

Carina Double Sided Wall Mount IP Display

Model No: WL-IPD-SPKR-510D-CAR-F

Specification Submittal

Dimensions

Front View

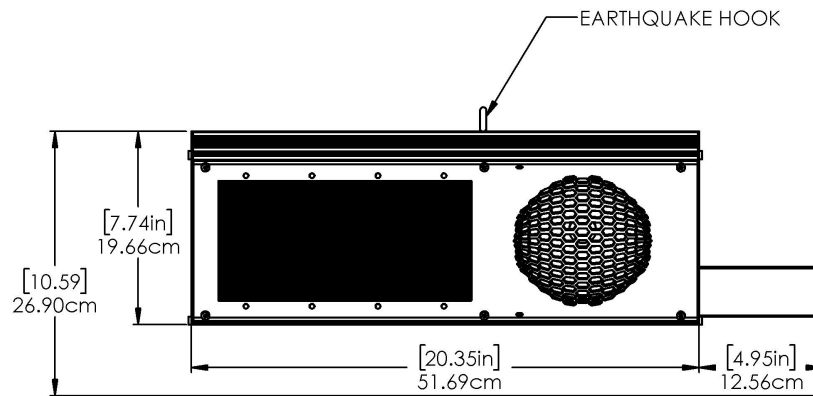

Side View

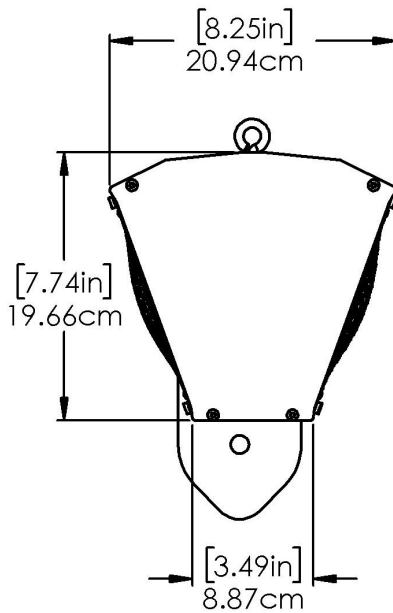

Bracket Side View

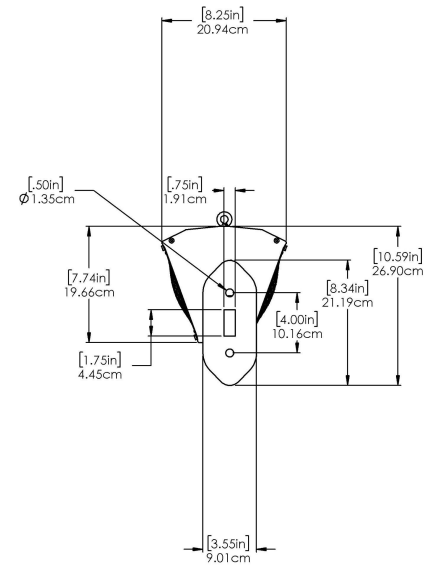

Job Name:

Date:

Location:

Notes:





Carina Double Sided Wall Mount IP Display

Model No: WL-IPD-SPKR-510D-CAR-F

Specification Submittal

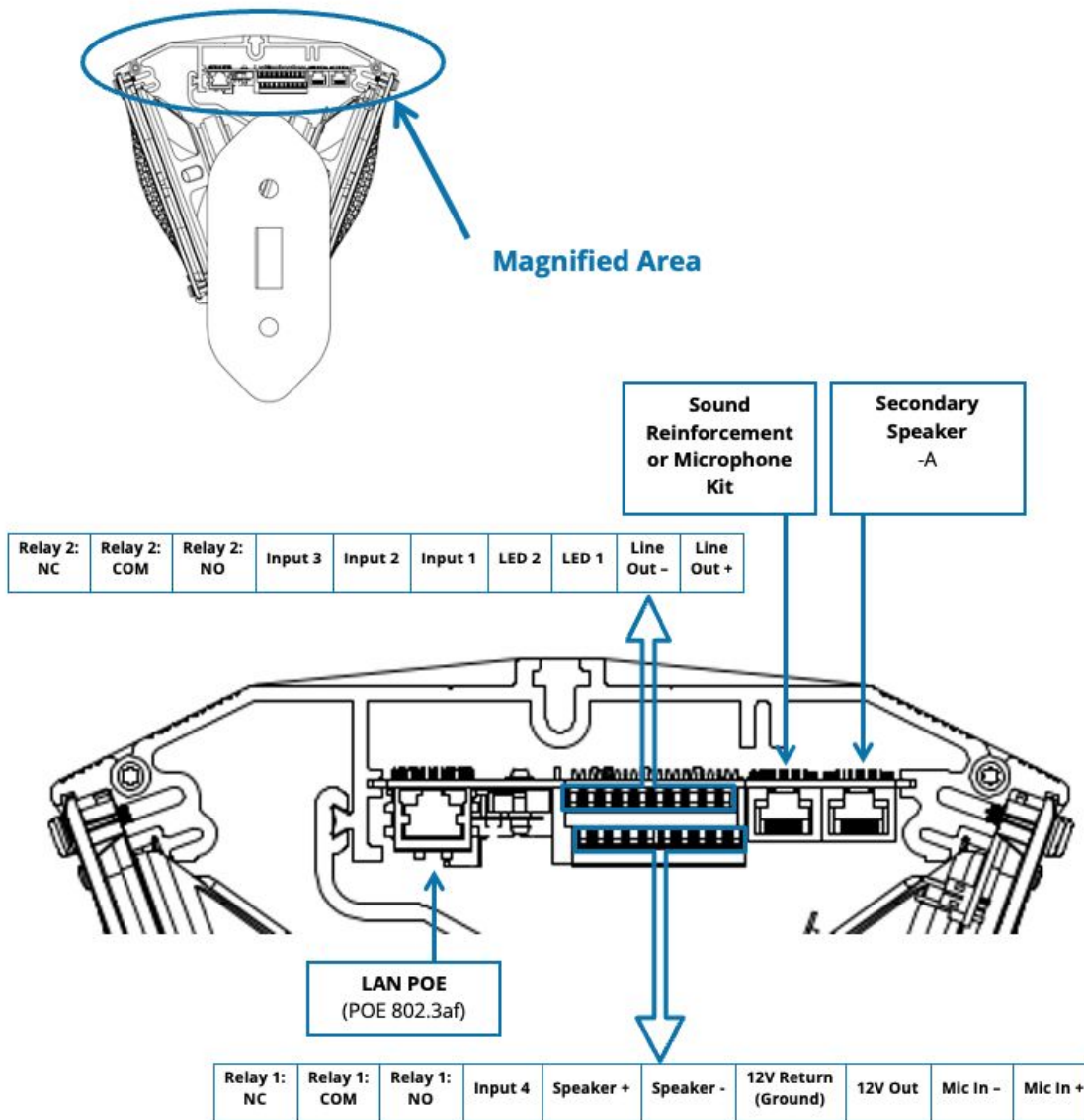
Wiring Diagram



Job Name:	Date:	Location:
Notes:		

Carina Double Sided Wall Mount IP Display

Model No: WL-IPD-SPKR-510D-CAR-F

Specification Submittal

Terminal Blocks

MIC IN +	Unused
MIC IN -	Unused
12 V OUT	Fused, nominal 12V output, max 0.5A. Subject to power capabilities of PoE.
12 V RTN (GND)	Ground
SPKR -	Unused
SPKR +	Unused
INPUT 4	Contact closure to ground (12 V RTN). Connect a Volume Button or SNMP Variable/Trap contact using <i>Input 4</i> and 12 V RTN (GND).
RELAY 1: NO	Isolated dry contact closure. Normally Open.
RELAY 1: COM	Isolated dry contact closure. Common.
RELAY 1: NC	Isolated dry contact closure. Normally Closed.
LINE OUT +	Consumer line input level (-10dBV)
LINE OUT -	Consumer line input level (-10dBV)
LED 1	Unused
LED 2	Unused
INPUT 1	Contact closure to ground (12 V RTN). Connect a Panic/Call Button using <i>Input 1</i> and 12 V RTN (GND).
INPUT 2	Contact closure to ground (12 V RTN). Connect a Volume Button or SNMP Variable/Trap contact using <i>Input 2</i> and 12 V RTN (GND).
INPUT 3	Contact closure to ground (12 V RTN). Connect a Volume Button or SNMP Variable/Trap contact using <i>Input 3</i> and 12 V RTN (GND).
RELAY 2: NO	Isolated dry contact closure. Normally Open.
RELAY 2: COM	Isolated dry contact closure. Common.
RELAY 2: NC	Isolated dry contact closure. Normally Closed.

Carina Double Sided Wall Mount IP Display

Model No: WL-IPD-SPKR-510D-CAR-F

Specification Submittal

Mounting and Installation

To use Power-over-Ethernet (PoE 802.3af), route a Cat 5e or Cat 6 Ethernet cable from a PoE switch to the LAN/POE port. Once the unit is successfully powered, the LINK/ACTV indicator LED will begin to blink.

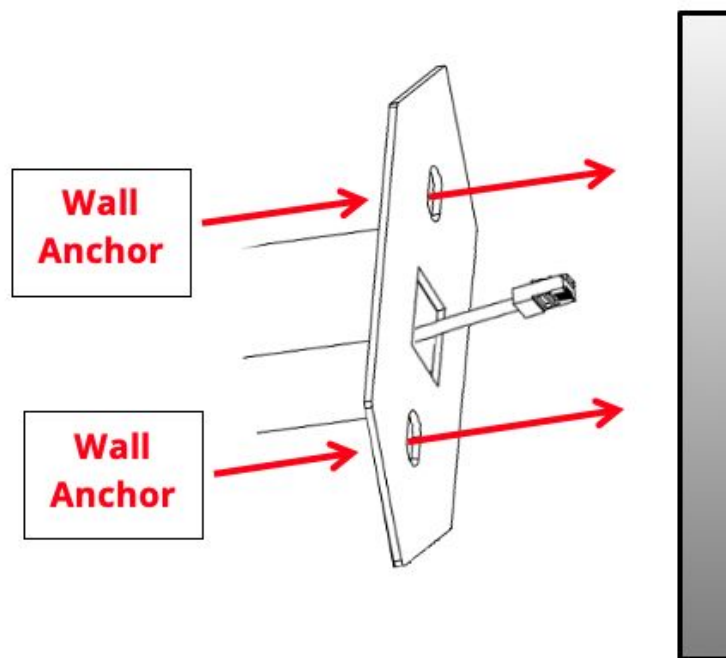

Affix mounting bracket to a solid, vertical wall surface using two bolts and anchors appropriate for the wall surface.

Route cabling through center, rectangular opening.

Job Name:	Date:	Location:
Notes:		

Carina Double Sided Wall Mount IP Display

Model No: WL-IPD-SPKR-510D-CAR-F

Specification Submittal

Mounting and Installation

Eye bolt has been pre-attached to the top of the IP Display. Attach an earthquake cable to eye bolt and secure to structure per local building and electrical codes.



Job Name:	Date:	Location:
Notes:		