



Carina Small IP Display

Model No: WL-IPD-SPKR-510-CAR

Description

The Carina Small IP Display supports auto-discovery by the Carina Event Manager and registration with SIP. With network connectivity, the device features a scrolling LED display and built-in speaker to convey both audio and visual alerts from the Carina Event Manager to occupants in the room. The settings for LED text, flasher color, brightness and duration are all fully customizable from the Event Manager. A built-in microphone allows for two-way intercom communication. The Event manager's NTP service provides an accurate time and date display when not broadcasting streaming events. The Carina IP Display can also power a second analog Wahsega speaker (WL-SPKR-xx-A) up to 20 meters away via PoE cable, increasing audio coverage in the space without requiring an additional cable home run.

Key Features

- PoE 802.3af enabled (Power-over-Ethernet)
- Industry-leading low standby power
- Fully configurable via Carina Event Manager
- Integrated microphone
- Two onboard relays for door control
- Compatible with standard call buttons
- Web-based mic and speaker volume control
- RJ45 connections for simplified installation
- One to three lines of text display
- Time set by network SNTP Server with no manual adjustments necessary
- Display 12- or 24-hour clock with four or six numerals
- Two color-configurable LED flashers
- One white LED flasher
- Built-in light sensor for energy-reducing auto-dim setting
- Text display is configurable
- 32,768 LED colors
- 32 x 64 resolution
- Text display up to 5" high

| | | |
|-----------|-------|---|
| Job Name: | Date: | Location: |
| Notes: | |  |

Specifications

- Ethernet: 10/100 Mbps
- Power Input: PoE 802.3af
- Standby power: <2 Watts
- Protocol: SIP RFC 3261 compatible
- Audio Codecs: 16-bit PCM (uncompressed), u-law (G.711u), a-law (G.711a), G.722, G.729
- Audio Sampling: 8 kHz, 16 kHz, or 32 kHz
- Speaker Drive Capabilities: 5W
- Speaker Impedance: 8Ω
- Speaker Sensitivity: 96dB 1W/0.5M SPL
- Coverage Angle: 120° / 4 kHz
- Dry Contact Relay Rating: 2A min, 250V AC, 24V DC
- Max PoE Cable Length: 100m (per standard) PoE 10/100 cable length
- Max Auxiliary Speaker Cable Length (Cat5e or Cat6): 20m
- Temperature Range: -40°C to +60°C
- Weight: 7.2lbs
- Overall Dimensions: 20.39" W x 7.1" H x 4.54" D
- LED Panel Dimensions: 5" tall x 10" wide
- Construction: Metal housing with polyester powdercoat paint
- Warranty: 3 years limited

Installation

Simple, surface mount wall installation with rear conduit access and side raceway access for wiring. Power supplied via Power over Ethernet (PoE) 802.3af.

Compatibility

Extension Speakers

- 2x2 Extension Ceiling Speaker - WL-SPKR-22-A
- Wall Mount Extension Speaker - WL-SPKR-SMT-A

Accessories

- Teacher Mic Kit - WL-MIC-WIR-KIT-1-CAR
- Sound Reinforcement Panel - WL-SPKR-RSR-W
- Call / Panic Button - WL-SPKR-RB-W

| | | |
|-----------|-------|---|
| Job Name: | Date: | Location: |
| Notes: | |  |

Carina Small IP Display

Model No: WL-IPD-SPKR-510-CAR

Specification Submittal

Dimensions

Front View

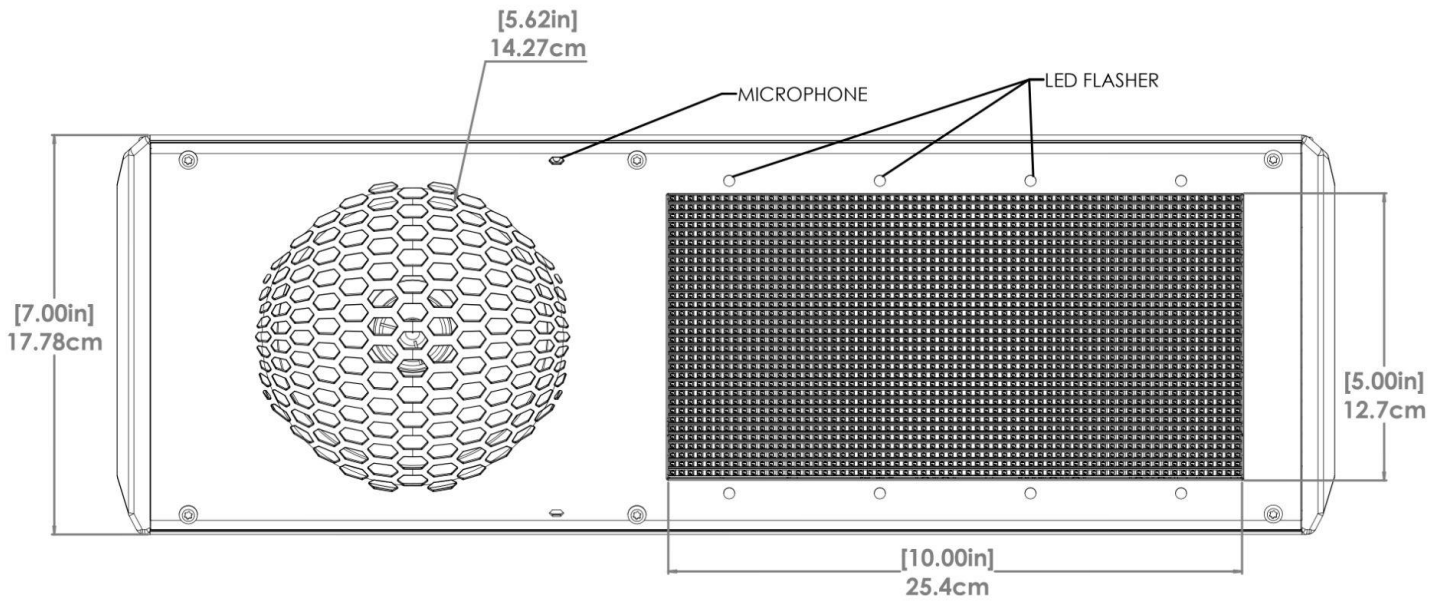

Back View

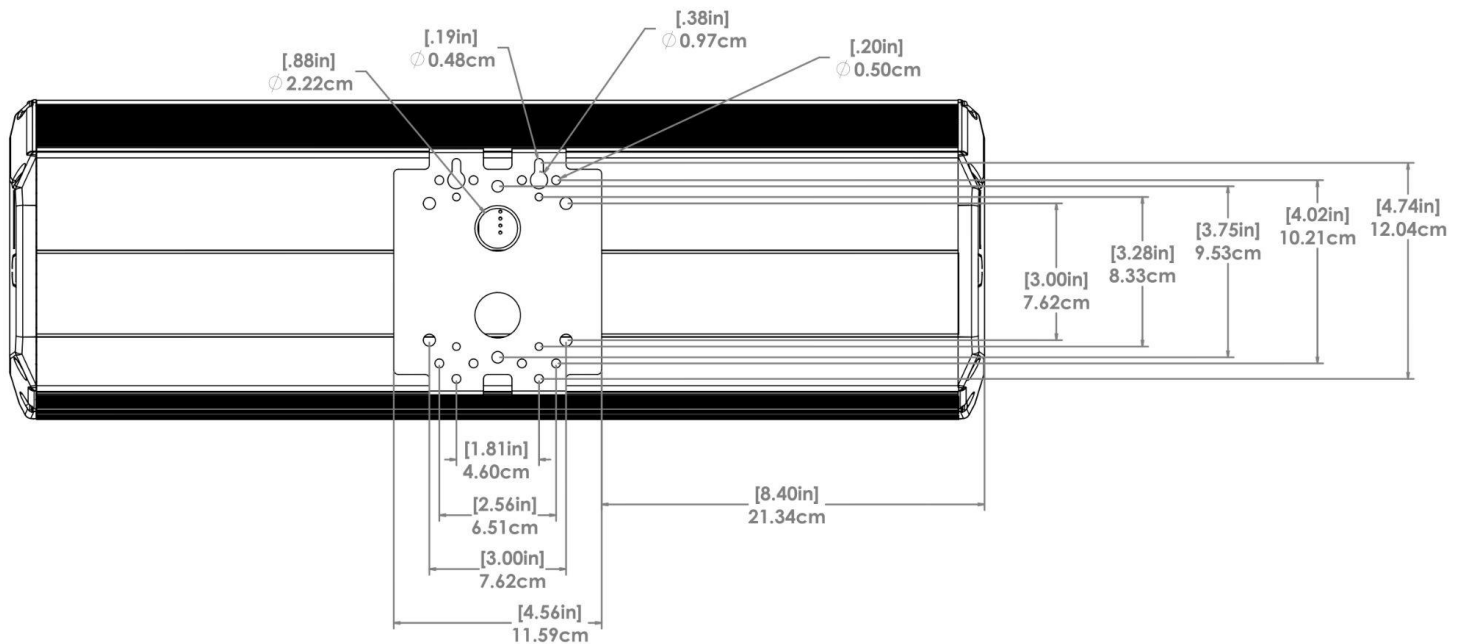



Carina Small IP Display

Model No: WL-IPD-SPKR-510-CAR

Specification Submittal

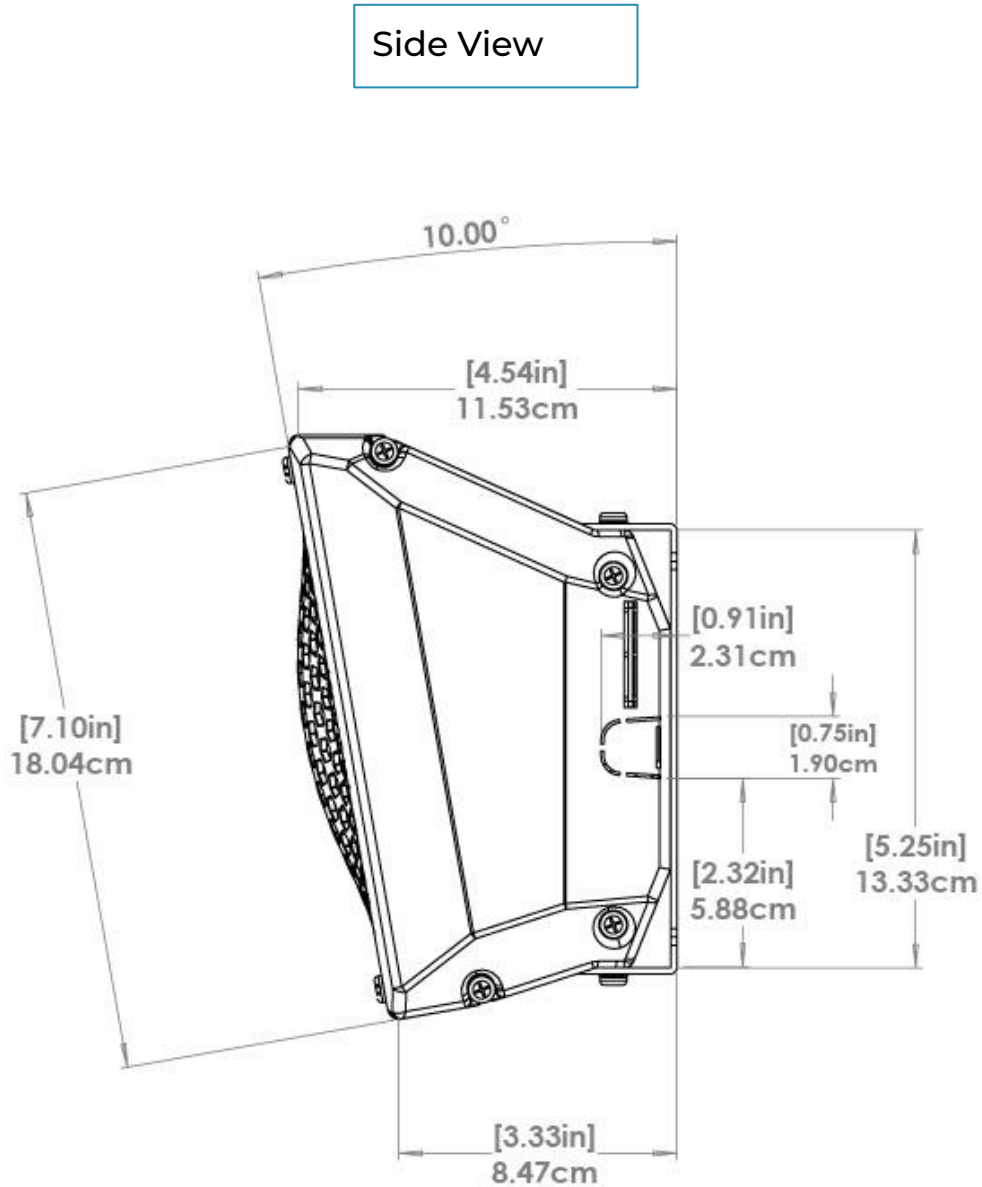
Dimensions



| | | |
|-----------|-------|---|
| Job Name: | Date: | Location: |
| Notes: | |  |

Carina Small IP Display

Model No: WL-IPD-SPKR-510-CAR

Specification Submittal

Wiring Diagram

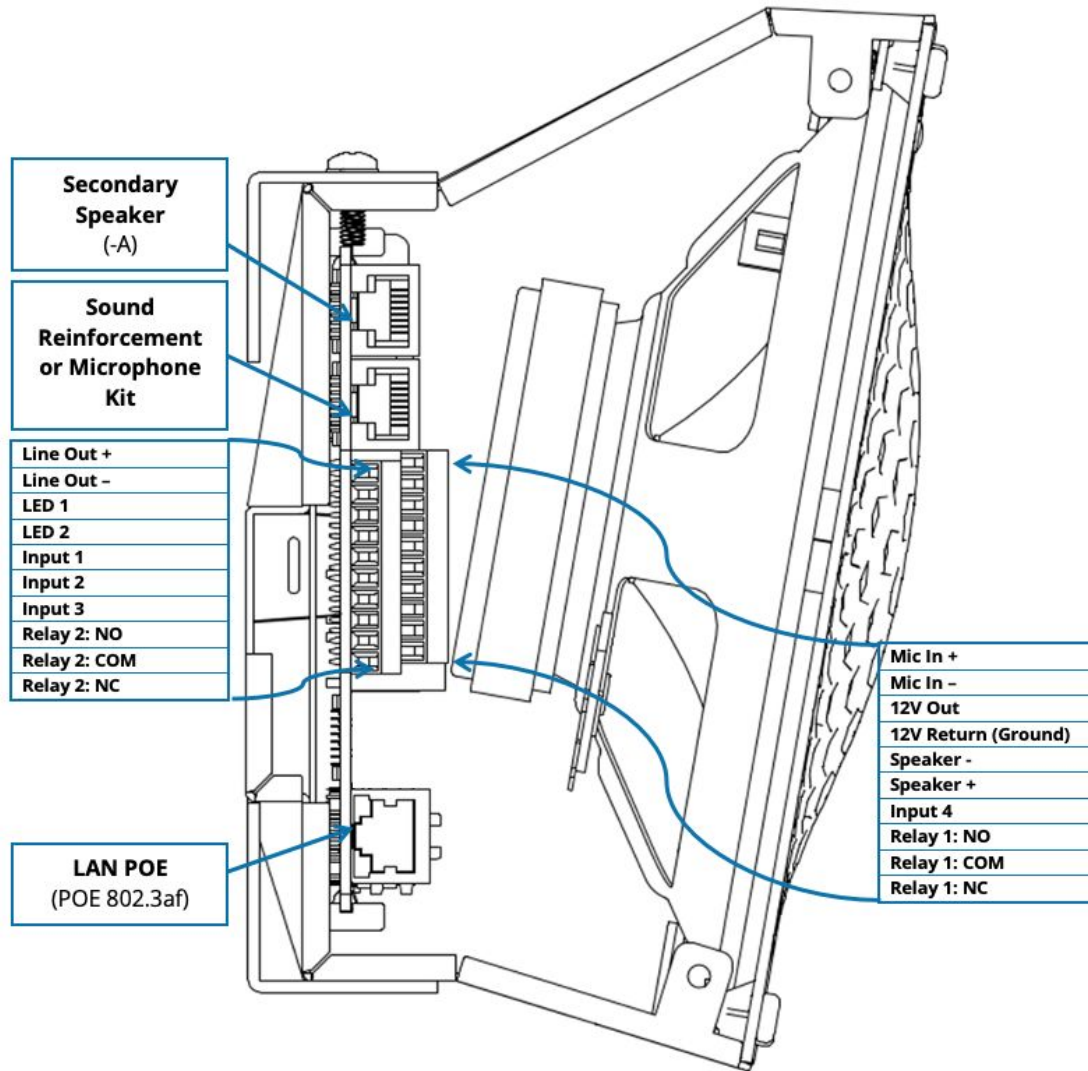

| | | |
|-----------|-------|---|
| Job Name: | Date: | Location: |
| Notes: | |  |

Terminal Blocks

| | |
|----------------|---|
| MIC IN + | Unused |
| MIC IN - | Unused |
| 12 V OUT | Fused, nominal 12V output, max 0.5A. Subject to power capabilities of PoE. |
| 12 V RTN (GND) | Ground |
| SPKR - | Unused |
| SPKR + | Unused |
| INPUT 4 | Contact closure to ground (<i>12 V RTN</i>). Connect a Volume Button or SNMP Variable/Trap contact using <i>Input 4</i> and <i>12 V RTN (GND)</i> . |
| RELAY 1: NO | Isolated dry contact closure. Normally Open. |
| RELAY 1: COM | Isolated dry contact closure. Common. |
| RELAY 1: NC | Isolated dry contact closure. Normally Closed. |
| LINE OUT + | Consumer line input level (-10dBV) |
| LINE OUT - | Consumer line input level (-10dBV) |
| LED 1 | Unused |
| LED 2 | Unused |
| INPUT 1 | Contact closure to ground (<i>12 V RTN</i>). Connect a Panic/Call Button using <i>Input 1</i> and <i>12 V RTN (GND)</i> . |
| INPUT 2 | Contact closure to ground (<i>12 V RTN</i>). Connect a Volume Button or SNMP Variable/Trap contact using <i>Input 2</i> and <i>12 V RTN (GND)</i> . |
| INPUT 3 | Contact closure to ground (<i>12 V RTN</i>). Connect a Volume Button or SNMP Variable/Trap contact using <i>Input 3</i> and <i>12 V RTN (GND)</i> . |
| RELAY 2: NO | Isolated dry contact closure. Normally Open. |
| RELAY 2: COM | Isolated dry contact closure. Common. |
| RELAY 2: NC | Isolated dry contact closure. Normally Closed. |

Carina Small IP Display

Model No: WL-IPD-SPKR-510-CAR

Specification Submittal

Installation

Please see cable routing installation video here - [https://bit.ly/SMT-Cable Installation](https://bit.ly/SMT-Cable_Installation)

Attach IP Display to bracket using included (8) #8-32 screws and washers.

Back View

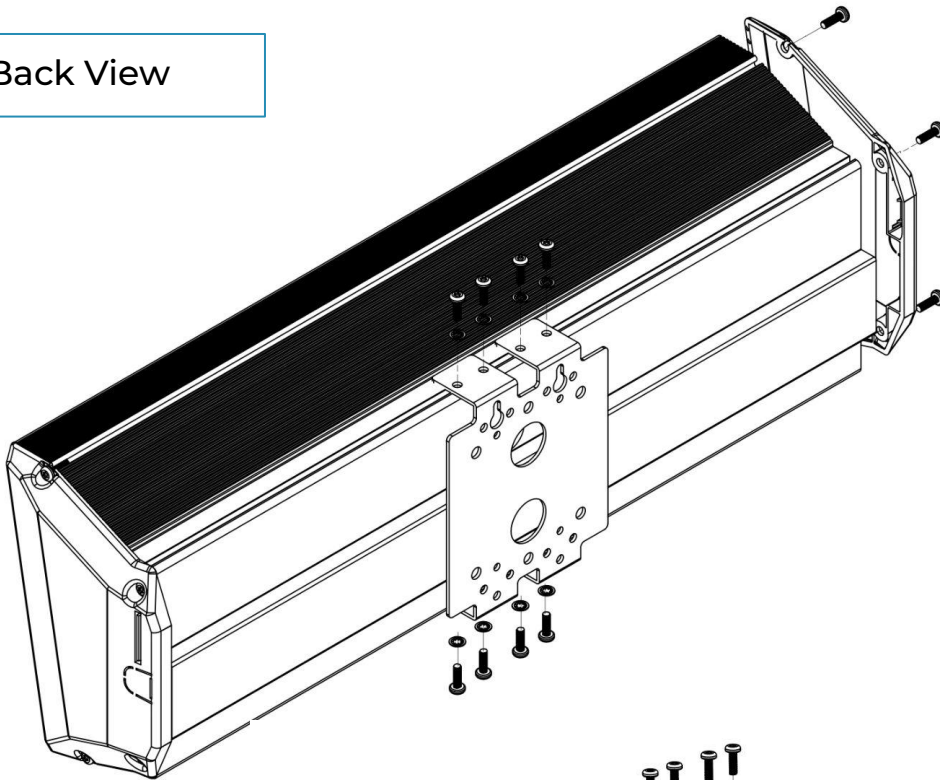

Front View

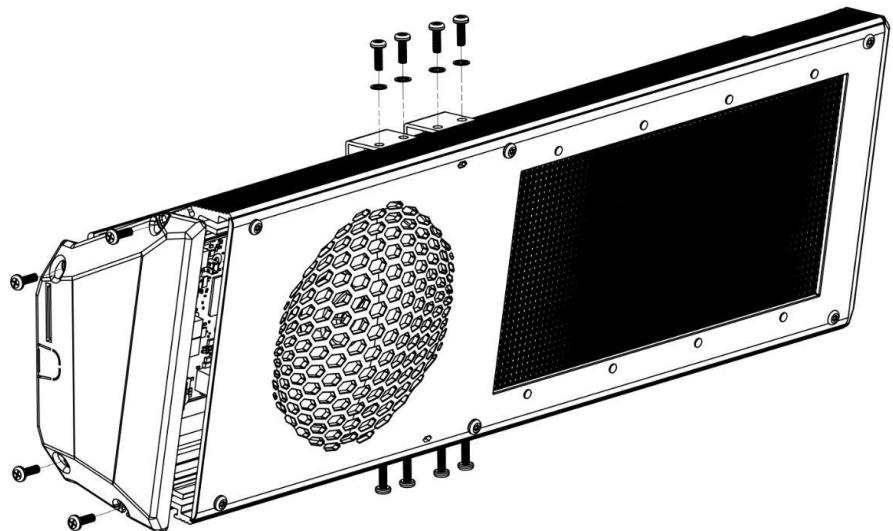

Mounting and Installation

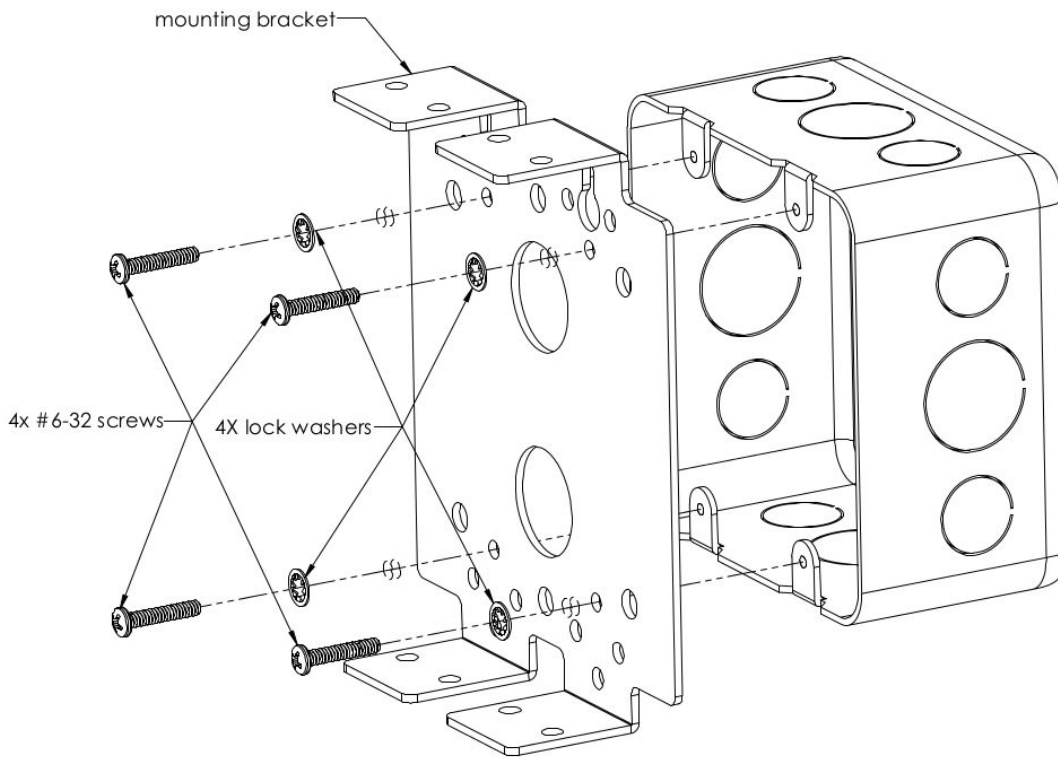

Mounting Bracket

Mount included bracket to the front of a standard two-gang electrical backbox (preferred), using (4) included #6-32 screws and lock washers. If mounting bracket to a solid surface rather than to an electrical backbox, use the appropriate bolts and anchors for that surface.

| | | |
|-----------|-------|---|
| Job Name: | Date: | Location: |
| Notes: | |  |